

MAXIM

MAX4444 Evaluation Kit

General Description

The MAX4444 evaluation kit (EV kit) simplifies evaluation of the MAX4444 ultra-fast differential line receiver. The EV kit includes the MAX4444, which has a fixed gain of +2V/V. This EV kit can also be used to evaluate the adjustable-gain MAX4445, which is stable with a minimum gain of +2V/V. To evaluate the MAX4445, order a free sample of the MAX4445ESE along with the MAX4444 EV kit.

Component List

DESIGNATION	QTY	DESCRIPTION
C1, C3	2	4.7 μ F \pm 20%, 10V tantalum capacitors AVX TAJA475M010R
C2, C4	2	0.1 μ F ceramic capacitors
R1, R2, R3	3	49.9 Ω \pm 1% resistors
R4	1	1M Ω \pm 5% resistor
R _G	0	Not installed
JU1	1	2-pin header
None	1	Shunt (JU1)
IN-, IN+, OUT	3	SMA connectors
U1	1	MAX4444ESE (16-Pin SO)
None	1	MAX4444 EV kit PC board
None	1	MAX4444 EV kit data sheet
None	1	MAX4444/MAX4445 data sheet

Component Supplier

SUPPLIER	PHONE	FAX
AVX	803-946-0690	803-626-3123

Note: Please indicate that you are using the MAX4444 or MAX4445 when contacting the above component supplier.

Features

- ◆ 500MHz Full-Power Bandwidth
- ◆ 5000V/ μ s Slew Rate
- ◆ Proven PC Board Layout
- ◆ Fully Assembled and Tested Surface-Mount Board

Ordering Information

PART	TEMP. RANGE	IC PACKAGE
MAX4444EVKIT	0°C to +70°C	16 SO

Quick Start

The MAX4444 EV kit is fully assembled and tested. Follow these steps to verify board operation. **Do not turn on the power supply until all connections are completed.**

- 1) Connect a +5V power supply to the V_{CC} pin and a -5V power supply to the V_{EE} pin. Connect power-supply ground to the GND pads.
- 2) Ensure that the shunt is installed on jumper JU1.
- 3) Apply signals to IN+ and IN- whose differential voltage does not exceed \pm 1.5V. These signals must not exceed the amplifier's input common-mode range of -2.9V to +2.9V.
- 4) Connect the output marked OUT to a 50 Ω terminated oscilloscope input.
- 5) Turn on the power supply and verify the output signal on the oscilloscope. The output amplitude observed on the oscilloscope will be the same as the amplitude of the differential input. This is due to the multiplication of the gain of +2V/V with the voltage divider formed by the 49.9 Ω back-terminating resistor (R3) and the oscilloscope input termination.

Evaluate: MAX4444/MAX4445

MAX4444 Evaluation Kit

Detailed Description

Enable Control

The MAX4444 provides an enable pin (EN) to enable or disable the output. Table 1 lists the options available for the enable/disable control jumper (JU1). EN is a TTL/CMOS-logic level input.

Layout Considerations

The MAX4444 EV kit layout has been optimized for high-speed signals, with careful attention given to grounding, power-supply bypassing, and signal-path layout. The small, surface-mount, ceramic bypass capacitors (C2, C4) have been placed as close to the MAX4444 supply pins as possible. Signal traces have been kept as short as possible by using 0805-sized termination and gain-set resistors.

Table 1. Jumper JU1 Functions

SHUNT	MAX4444 ENABLE PIN	MAX4444 OUTPUT
Installed	Connected to VCC	MAX4444 enabled
Not installed	Pulled to GND through 1MΩ resistor (R4)	MAX4444 in shut-down

Evaluating the MAX4444

To evaluate the MAX4445, turn off the power to the EV kit. Replace the MAX4444 with a MAX4445ESE, and install gain-setting resistor R_G (0805, 1%) according to the following formula:

$$R_G = 600\Omega / (\text{gain} - 1)$$

Note: The gain must be at least +2V/V (R_G ≤ 600Ω) for the amplifier to be stable.

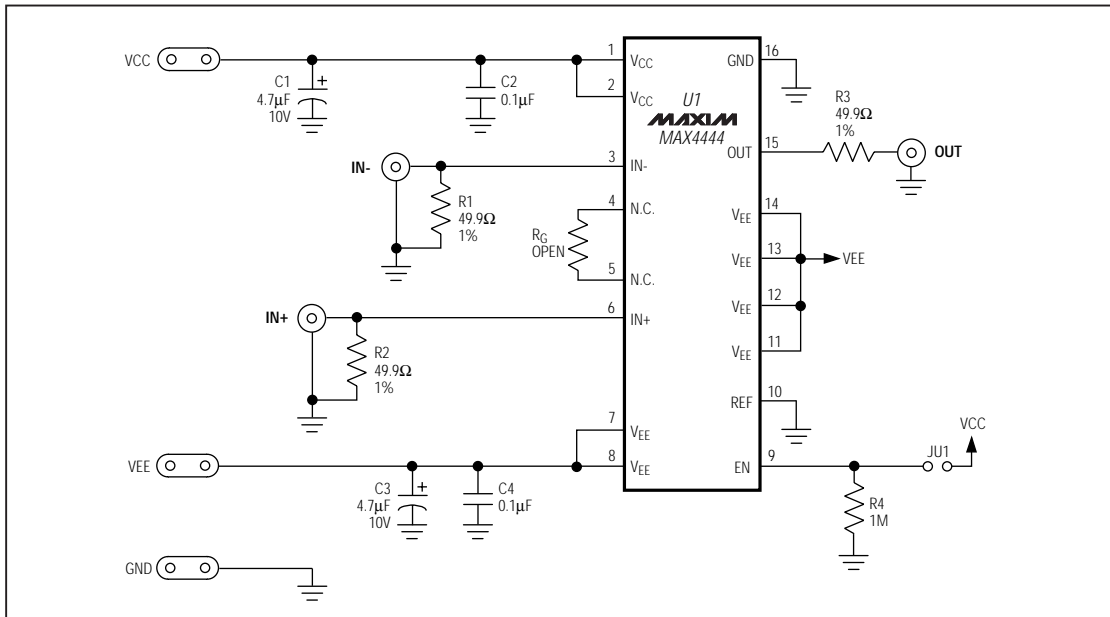

Figure 1. MAX4444 EV Kit Schematic

MAX4444 Evaluation Kit

Evaluate: MAX44444/MAX4445

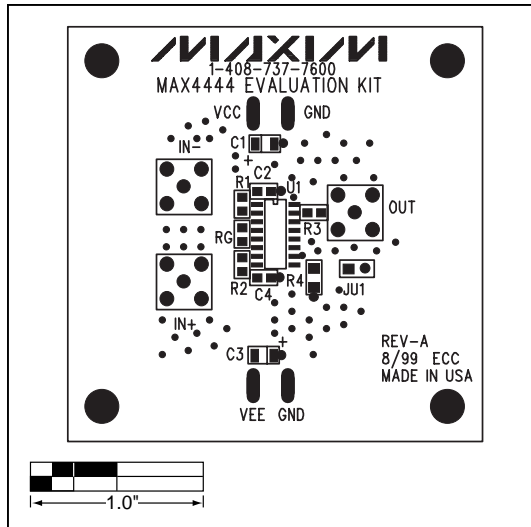

Figure 2. MAX4444 EV Kit Component Placement Guide—Component Side

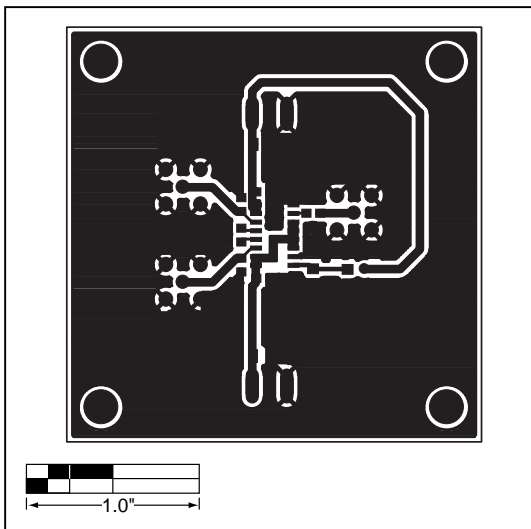

Figure 3. MAX4444 EV Kit PC Board Layout—Component Side

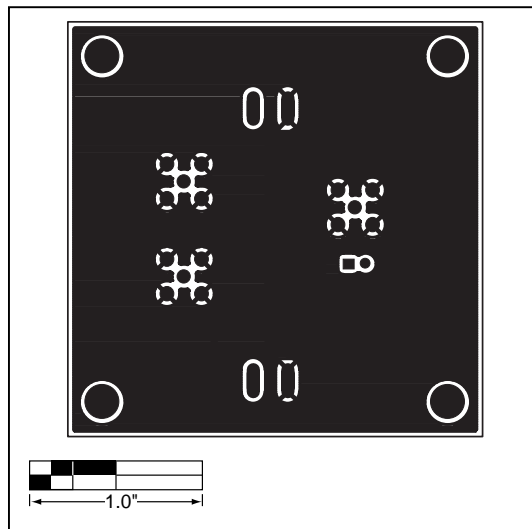

Figure 4. MAX4444 EV Kit PC Board Layout—Solder Side

MAX4444 Evaluation Kit

Evaluate: MAX4444/MAX4445

NOTES

Maxim cannot assume responsibility for use of any circuitry other than circuitry entirely embodied in a Maxim product. No circuit patent licenses are implied. Maxim reserves the right to change the circuitry and specifications without notice at any time.

4 _____ Maxim Integrated Products, 120 San Gabriel Drive, Sunnyvale, CA 94086 408-737-7600

© 1999 Maxim Integrated Products

Printed USA

MAXIM is a registered trademark of Maxim Integrated Products.